

forster unico  
forster unico HI



U<sub>d</sub> > 1.1 W/(m<sup>2</sup>·K)



E30/EW30  
EI30



RC 1-3



FB4 NS

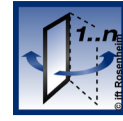

6

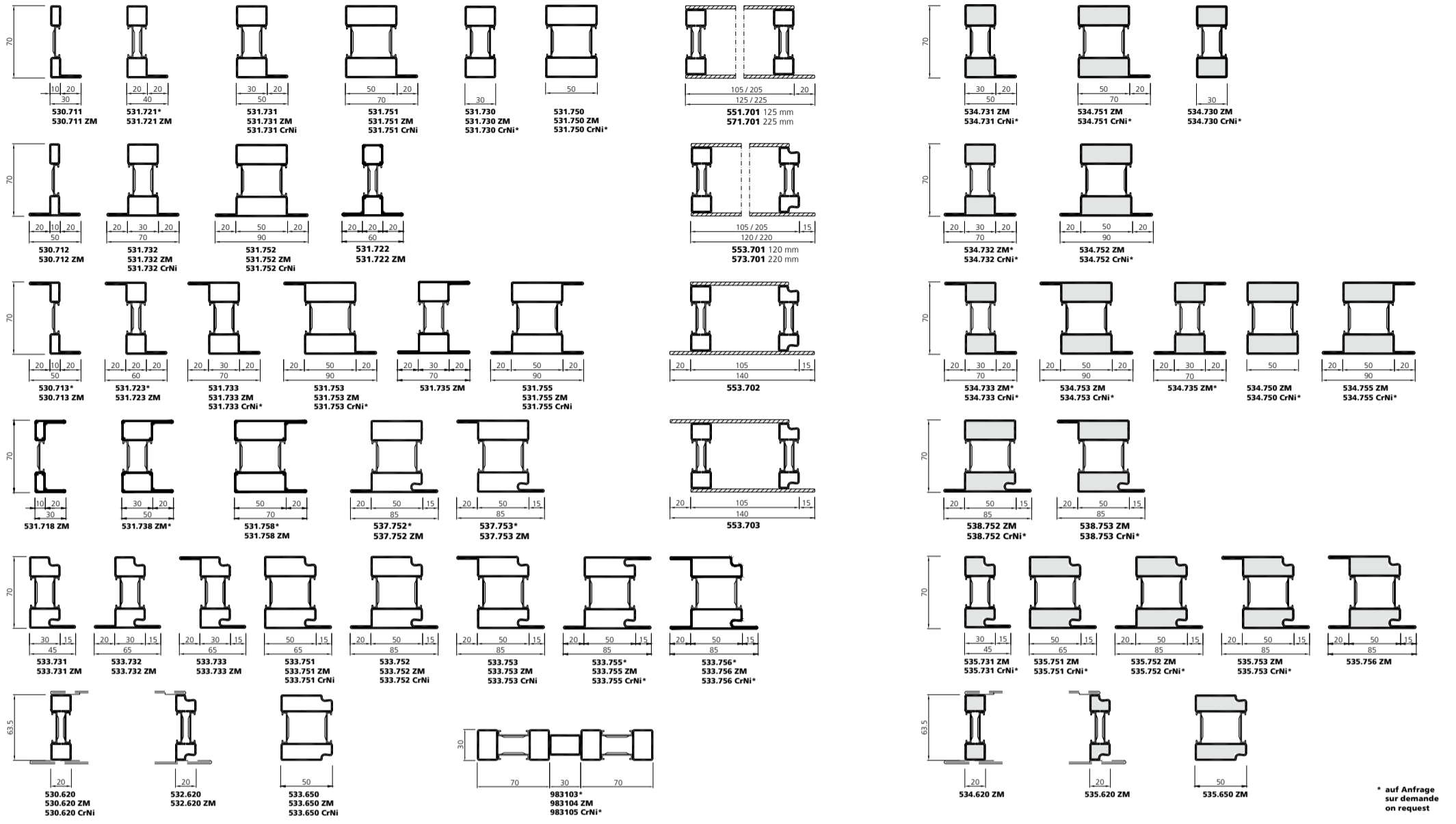

\* auf Anfrage  
sur demande  
on request

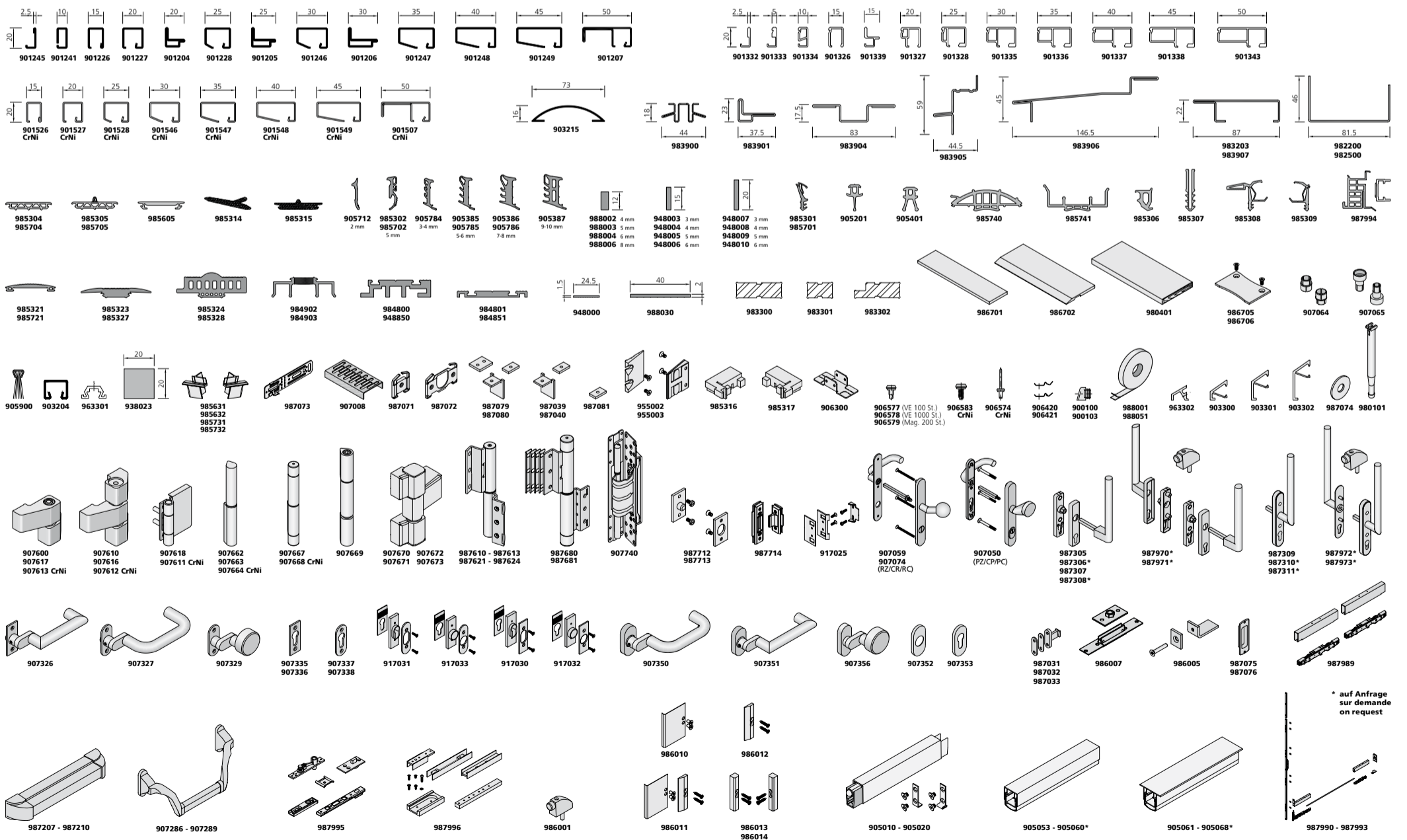

\* auf Anfrage  
sur demande  
on request

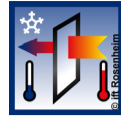

$U_w > 1.0 \text{ W/(m}^2\text{K)}$



E30/EW30  
EI30



RC 1-3



FB4 NS

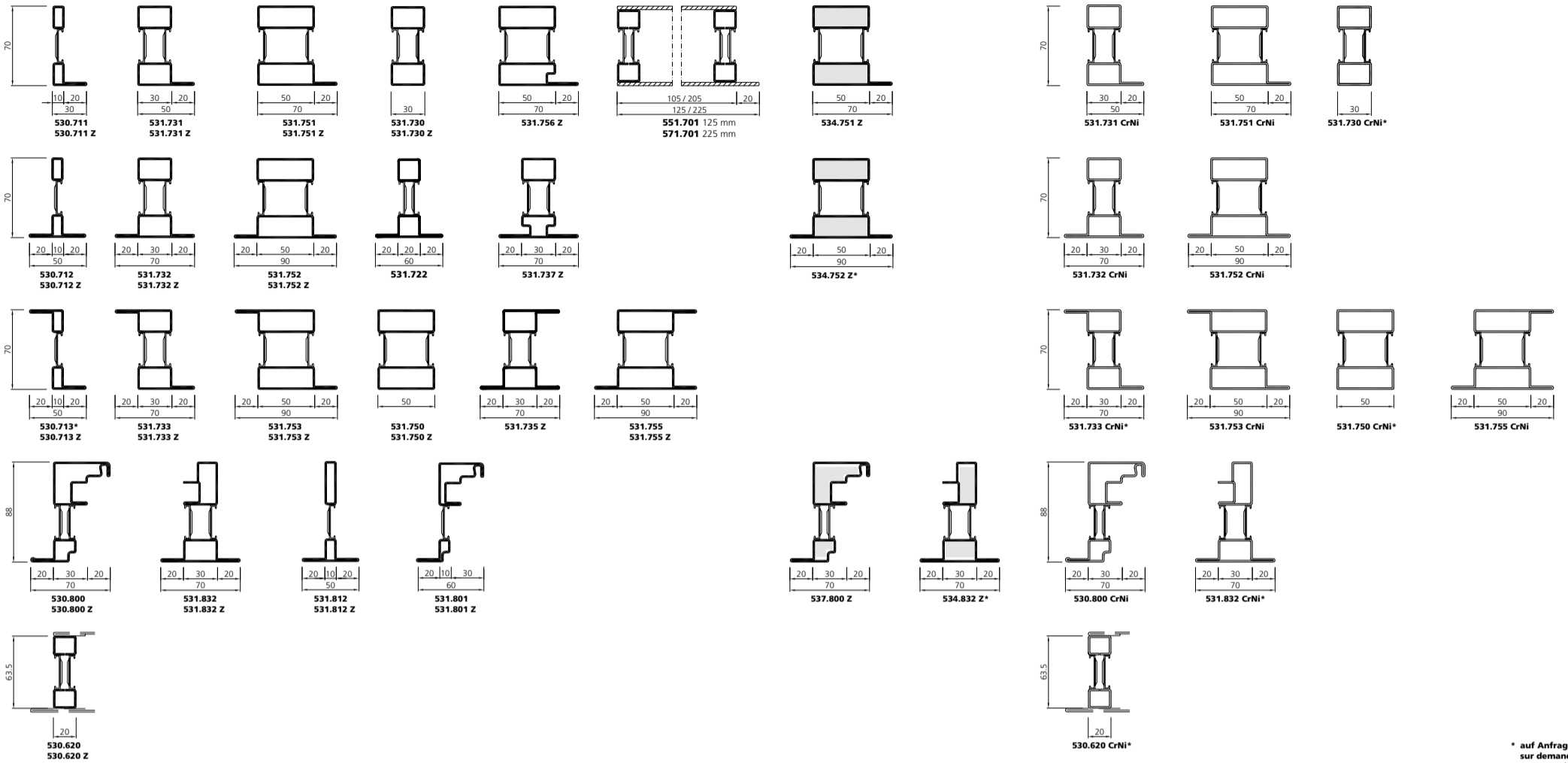

\* auf Anfrage  
sur demande  
on request

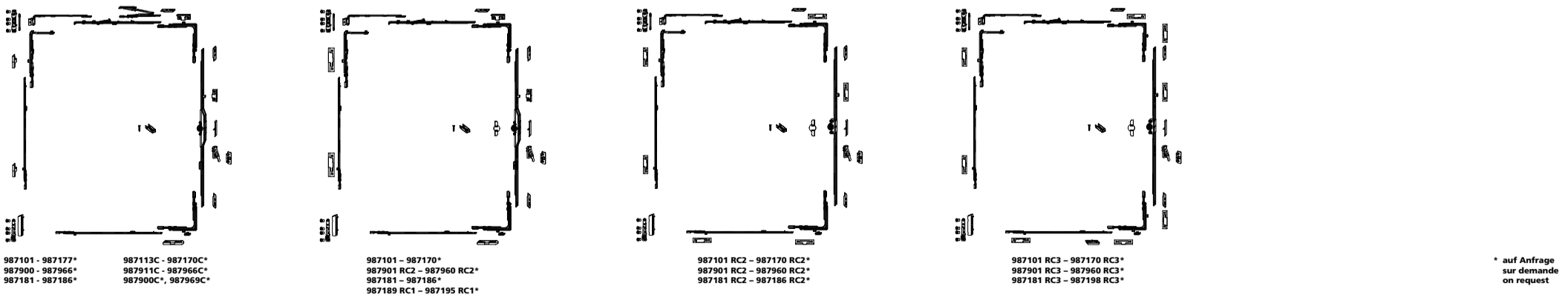
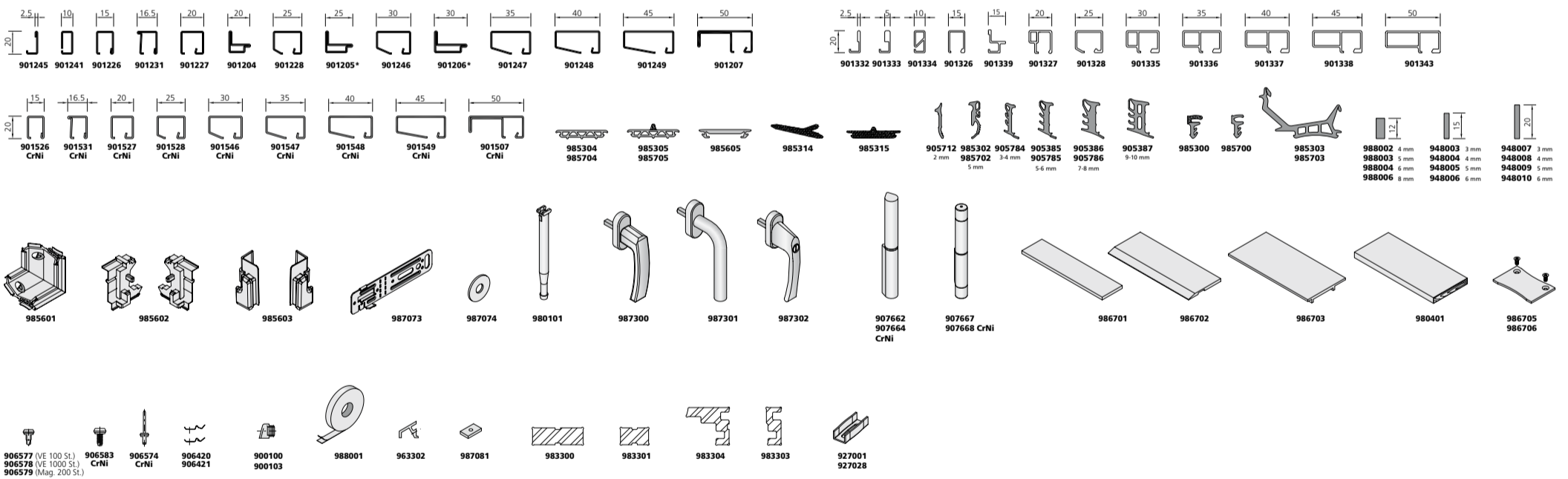

\* auf Anfrage  
sur demande  
on request

**forsterunico**<sup>®XS</sup>  
**forsterunico**<sup>®XSHI</sup>



$U_w > 0.8 \text{ W/(m}^2\text{K)}$



RC 2

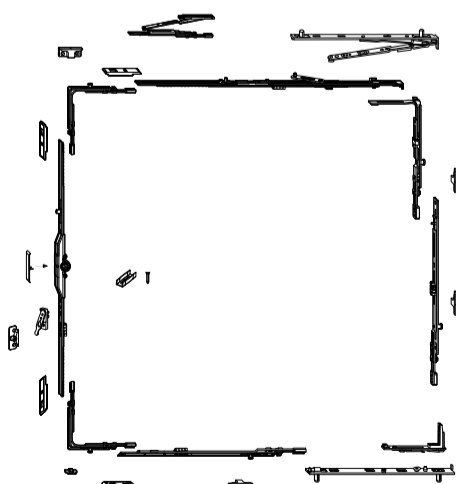
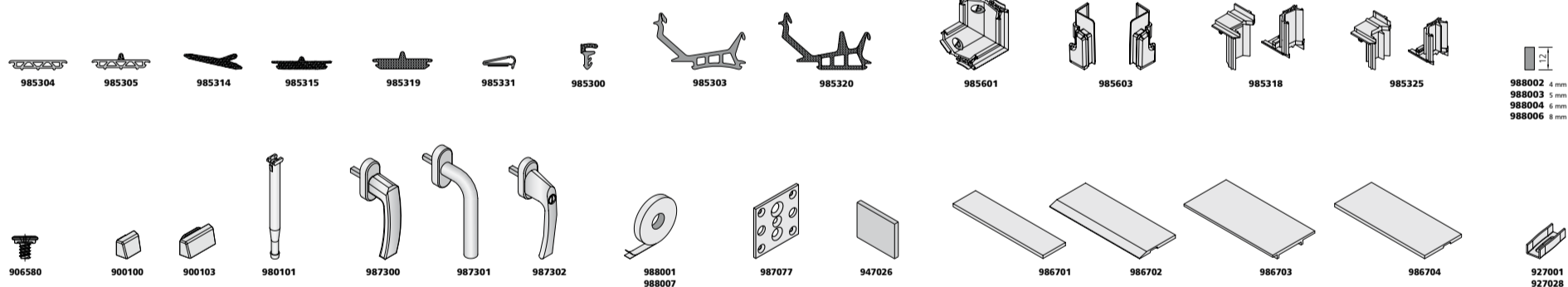
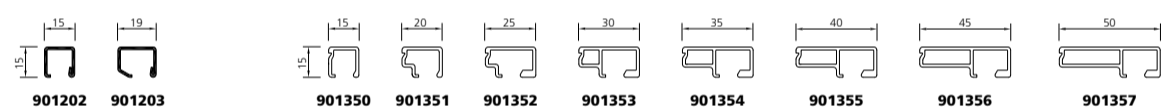
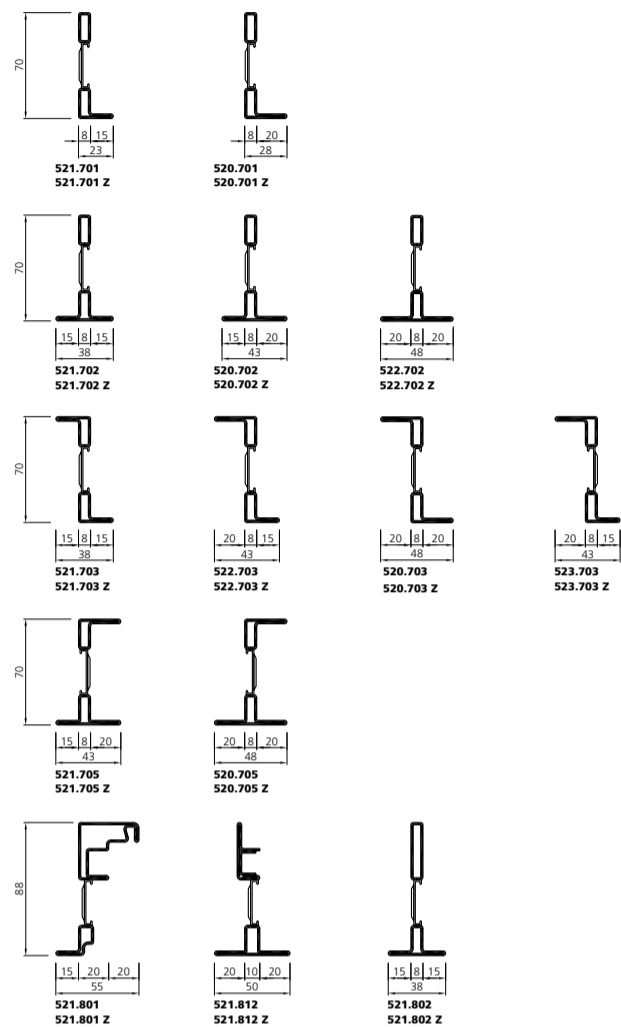

987101 R - 987166 R  
 987901 R - 987956 R

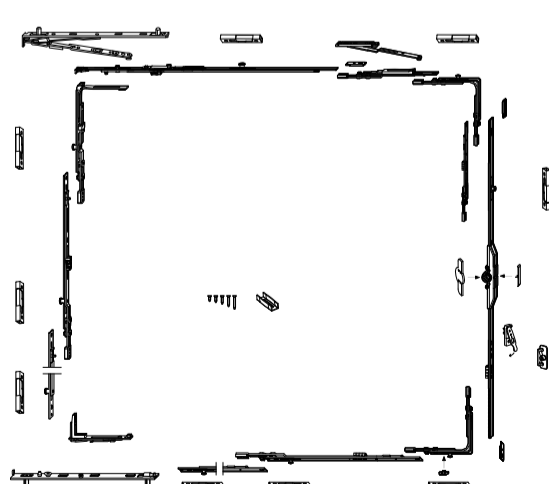

987113R RC2 - 987166R RC2  
 987911R RC2 - 987956R RC2

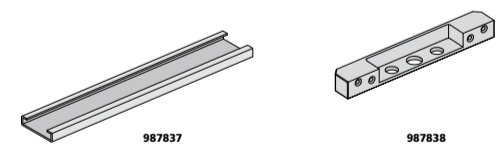









RC 1-3



Sa/S<sub>200</sub>



E30-E120/  
EW30-60

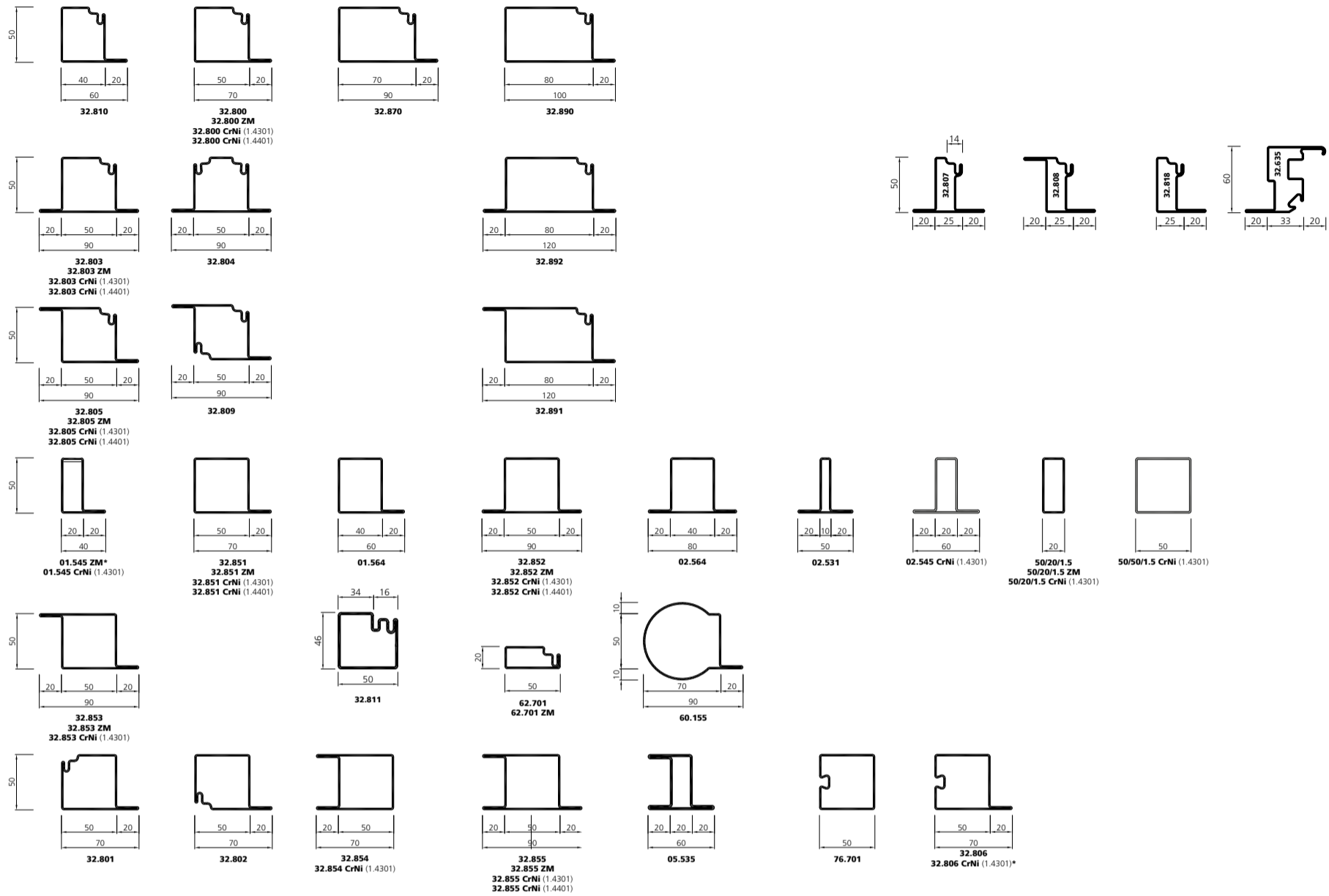

\* auf Anfrage  
sur demande  
on request

60S

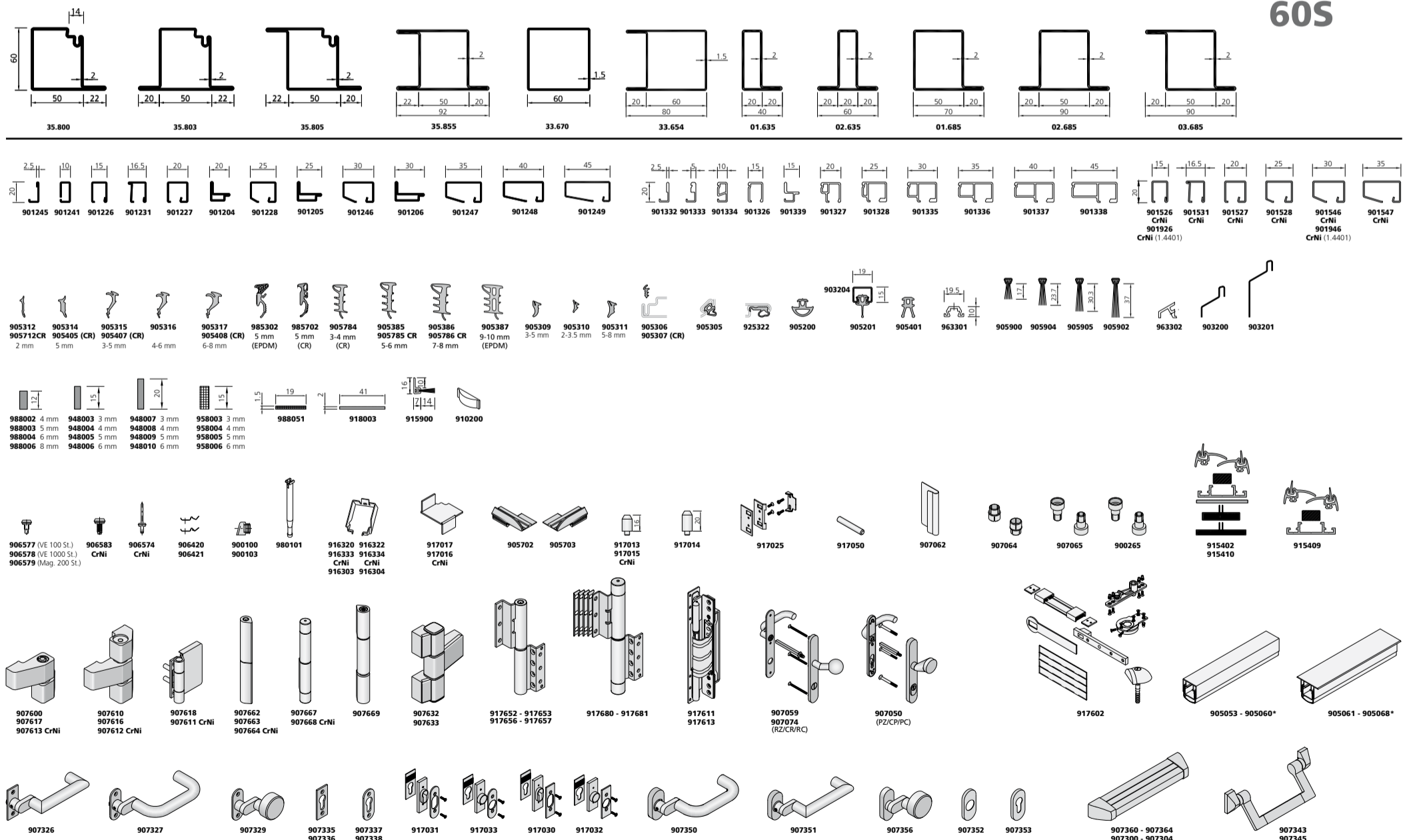

34

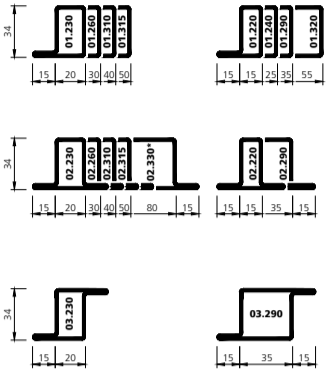

40

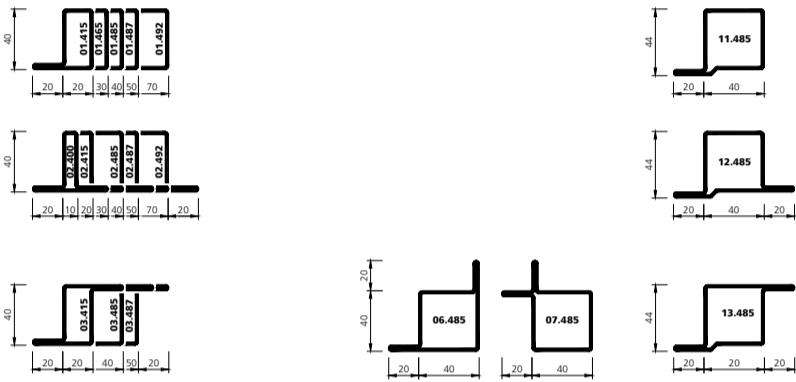

50

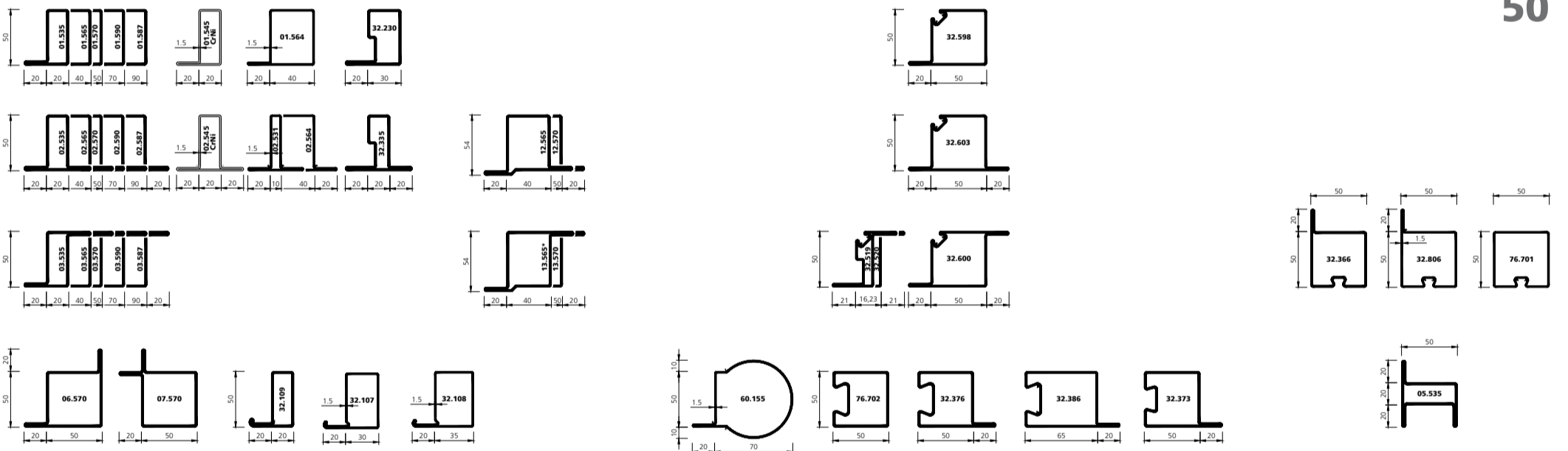

60

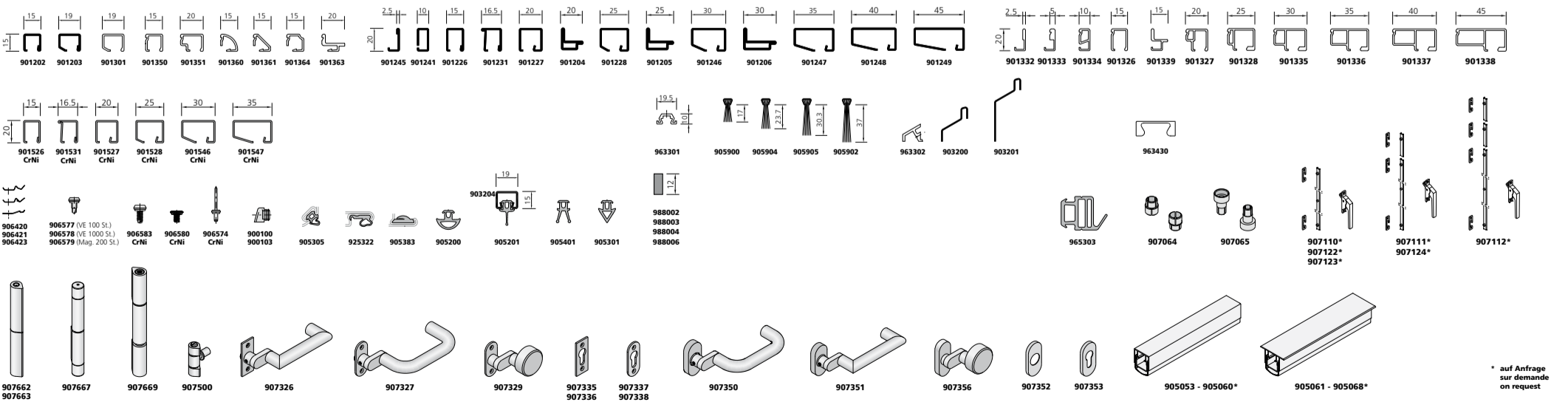
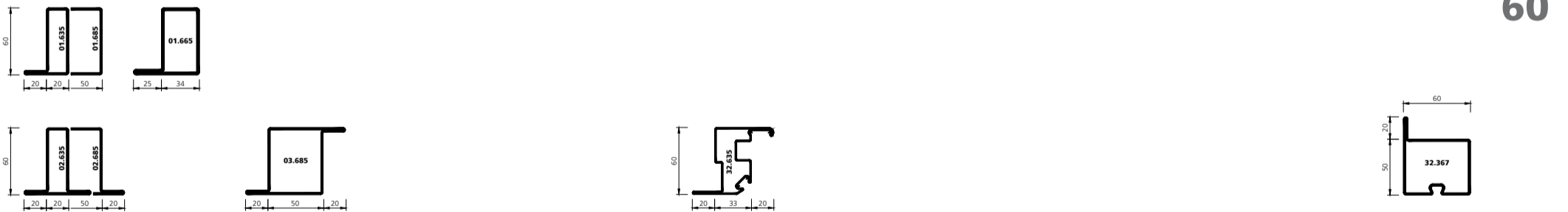

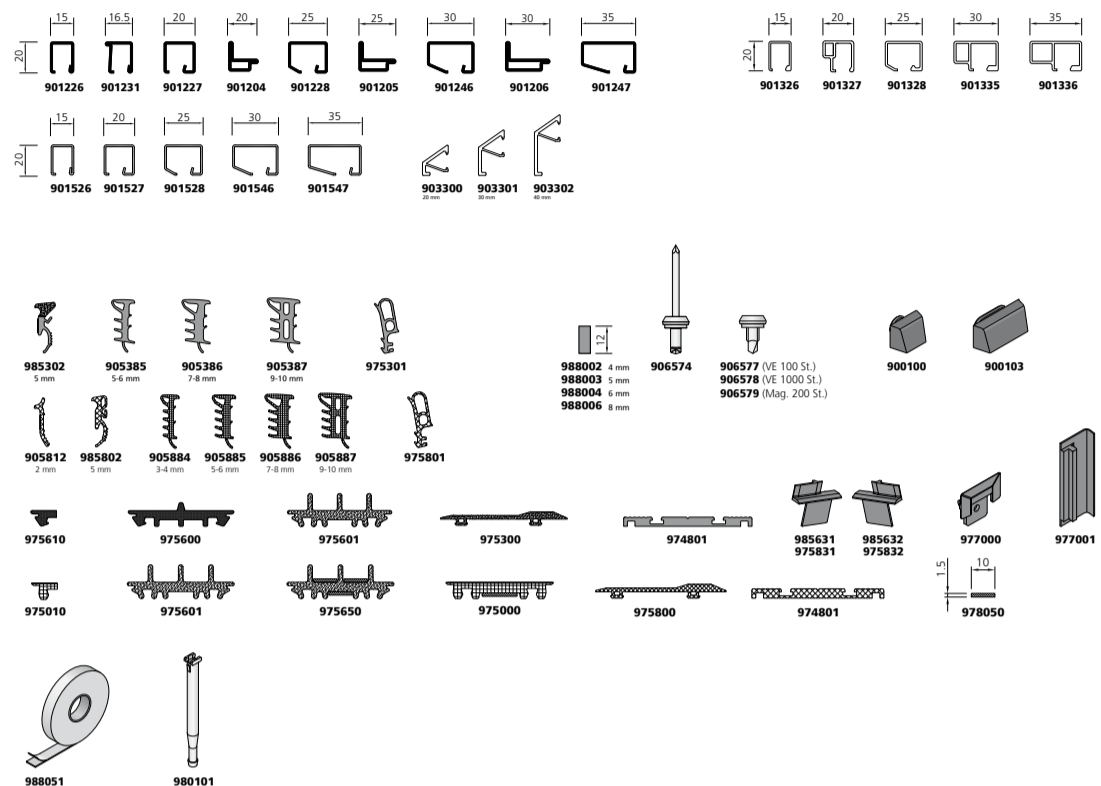
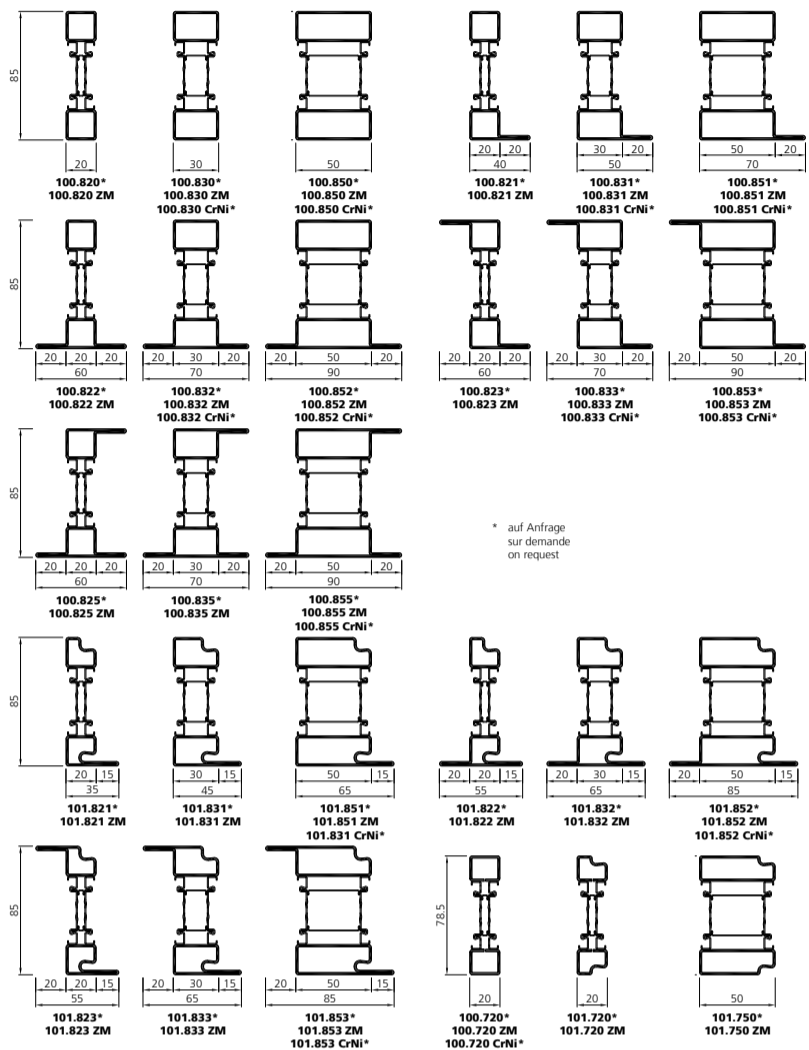

\* auf Anfrage  
sur demande  
on request

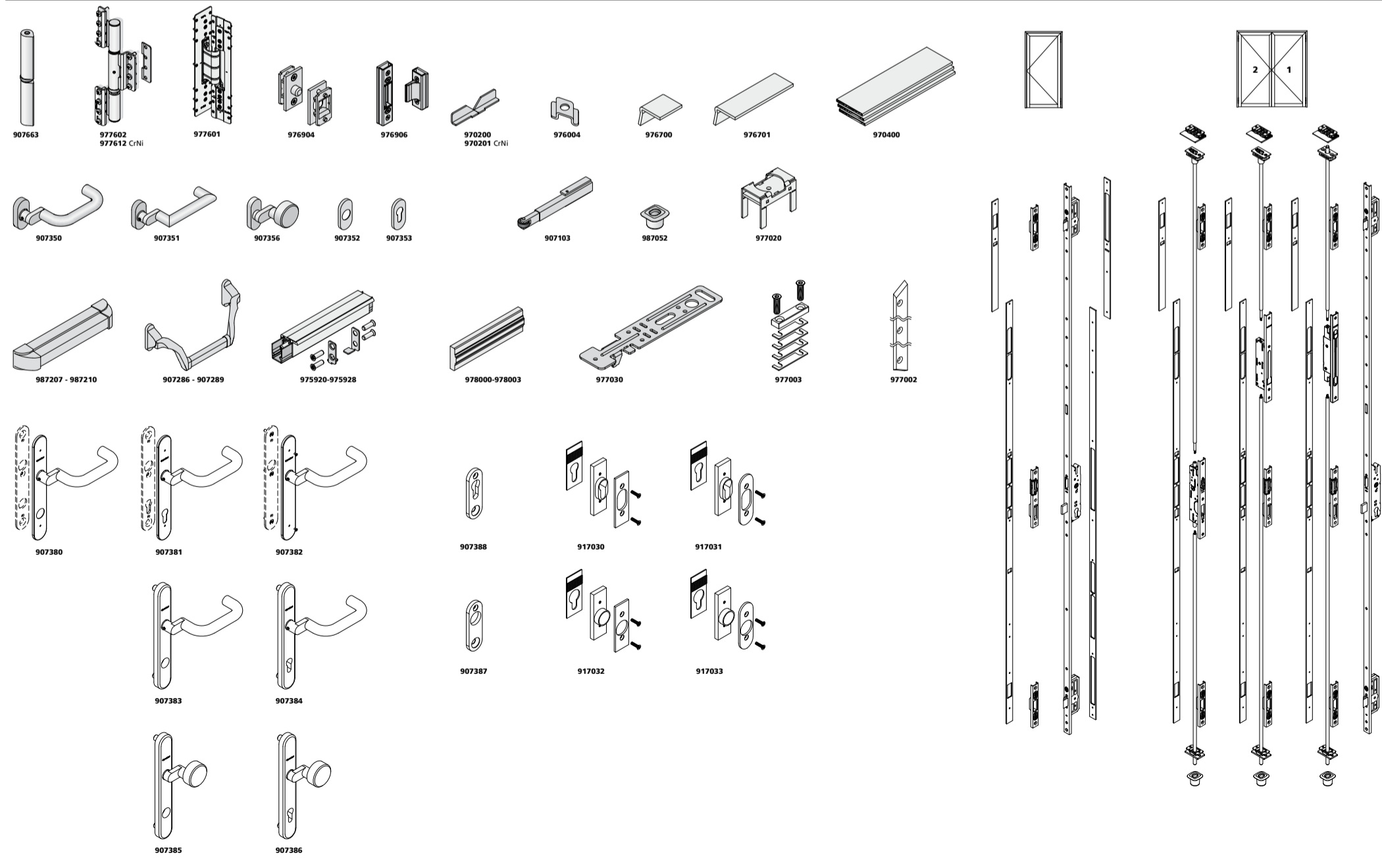

# forster omnia

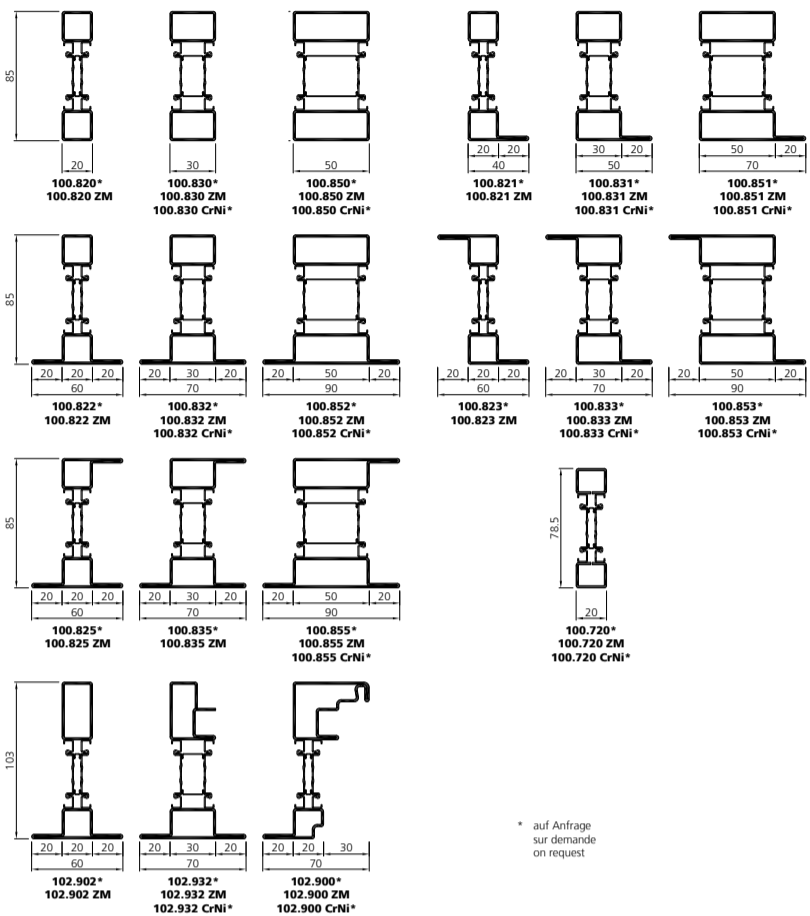

\* auf Anfrage  
sur demande  
on request

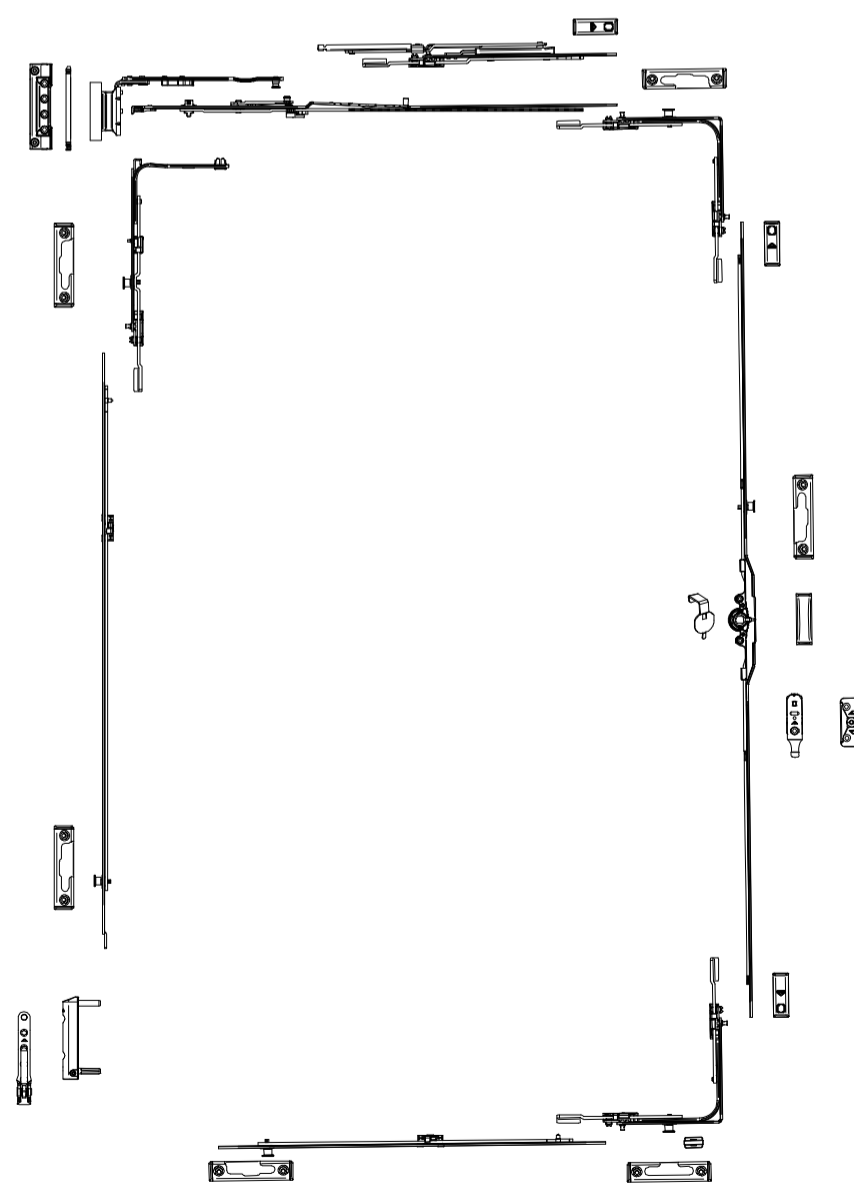
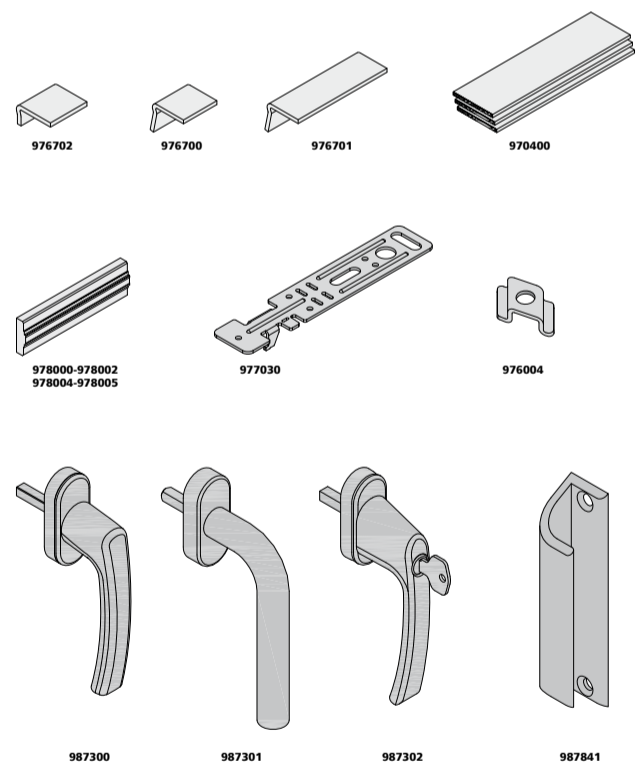
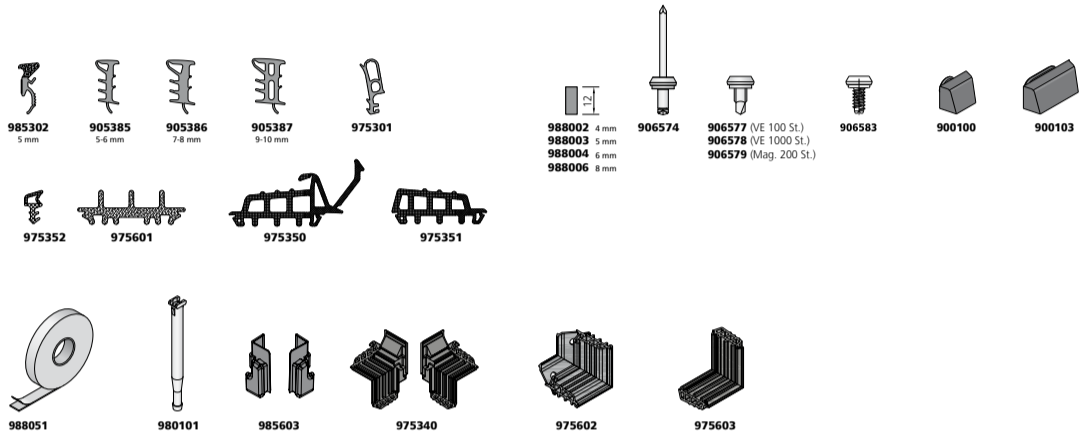
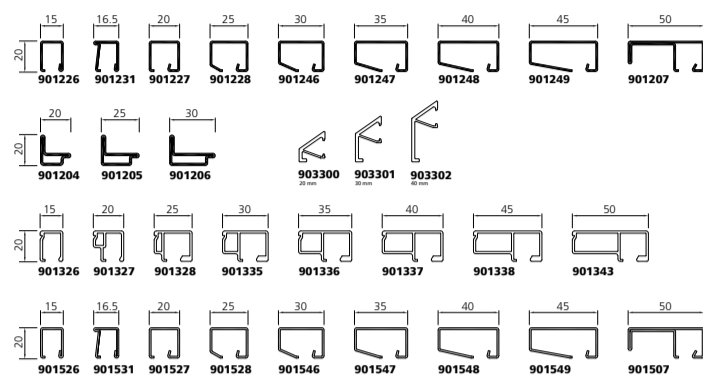

807126 - 807217  
807222 - 807233  
807426 - 807517

**forster**prestoxs

